

REVISION HISTORY					
ZONE	REV	DESCRIPTION	DATE	DWN	CHK
	A	RELEASED PER ECN 1078688			

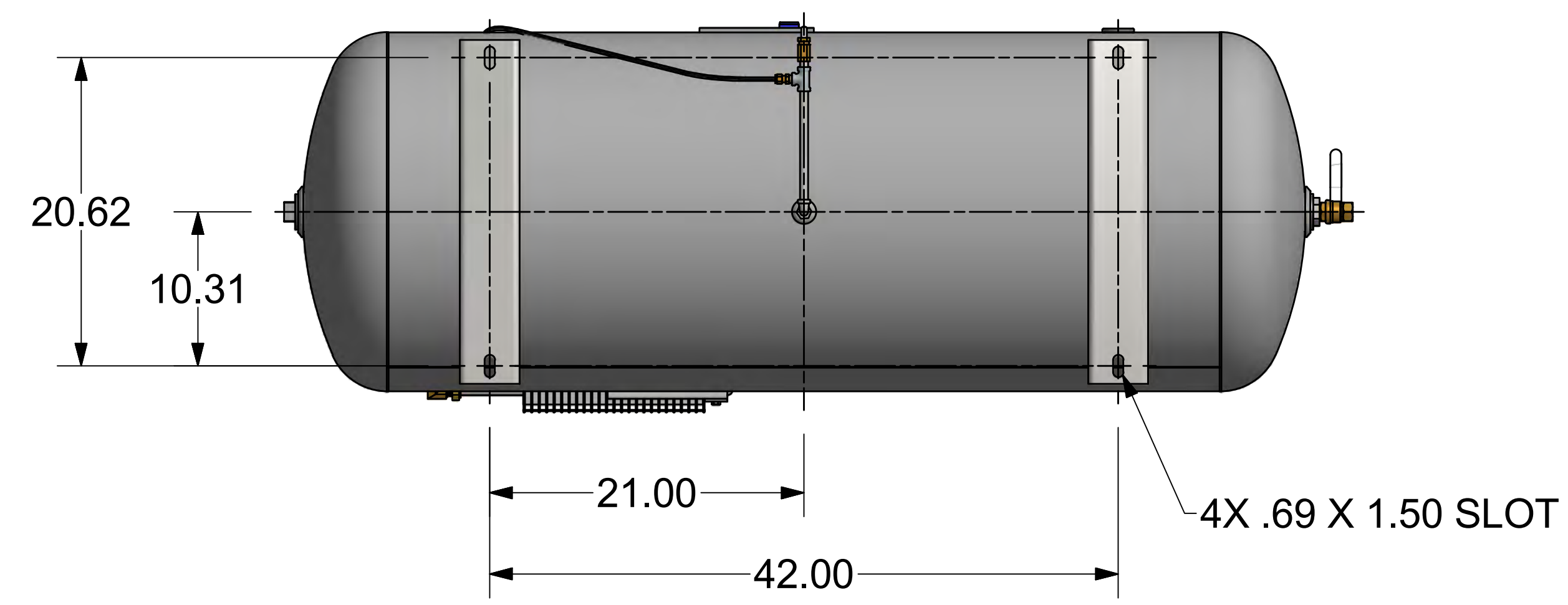
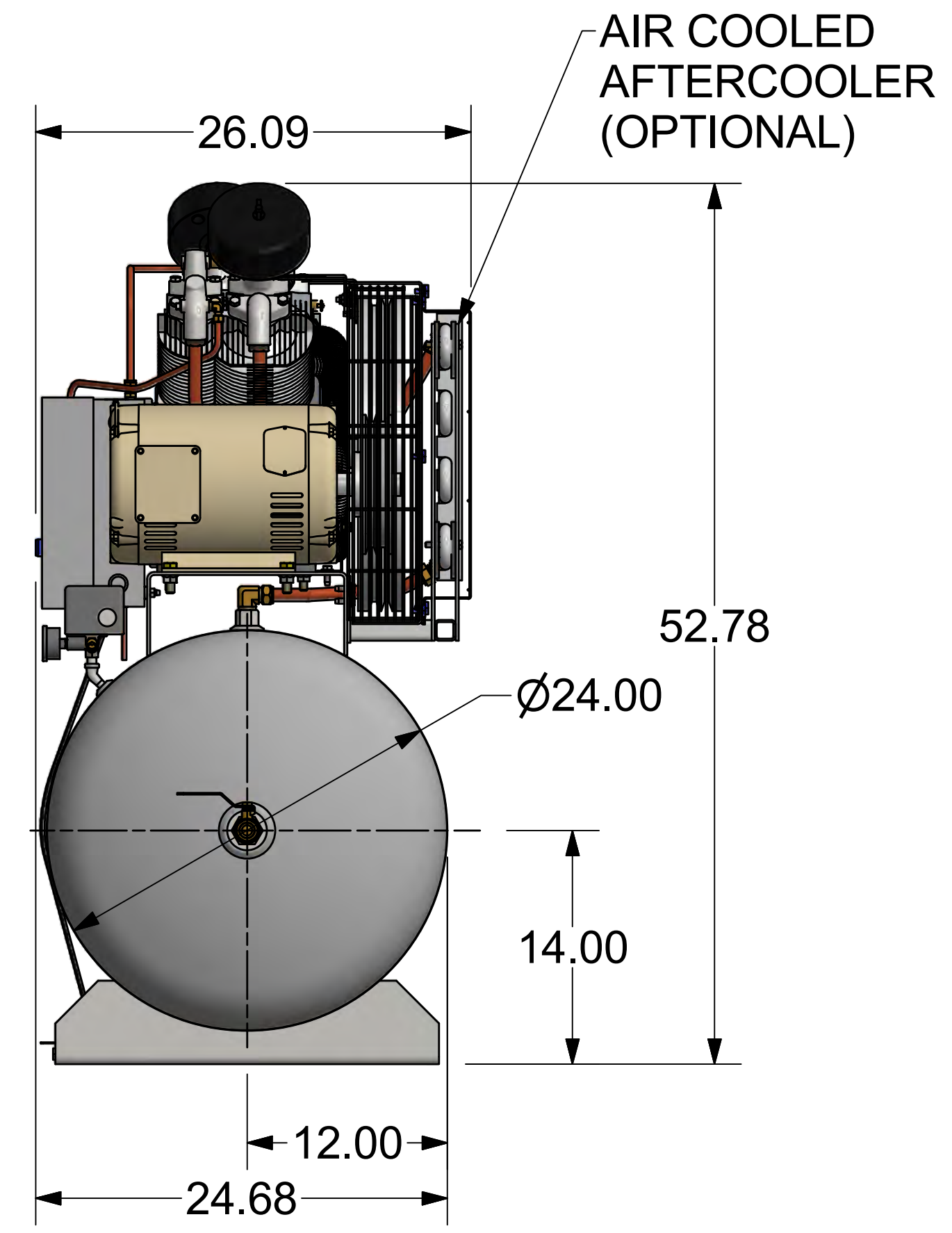
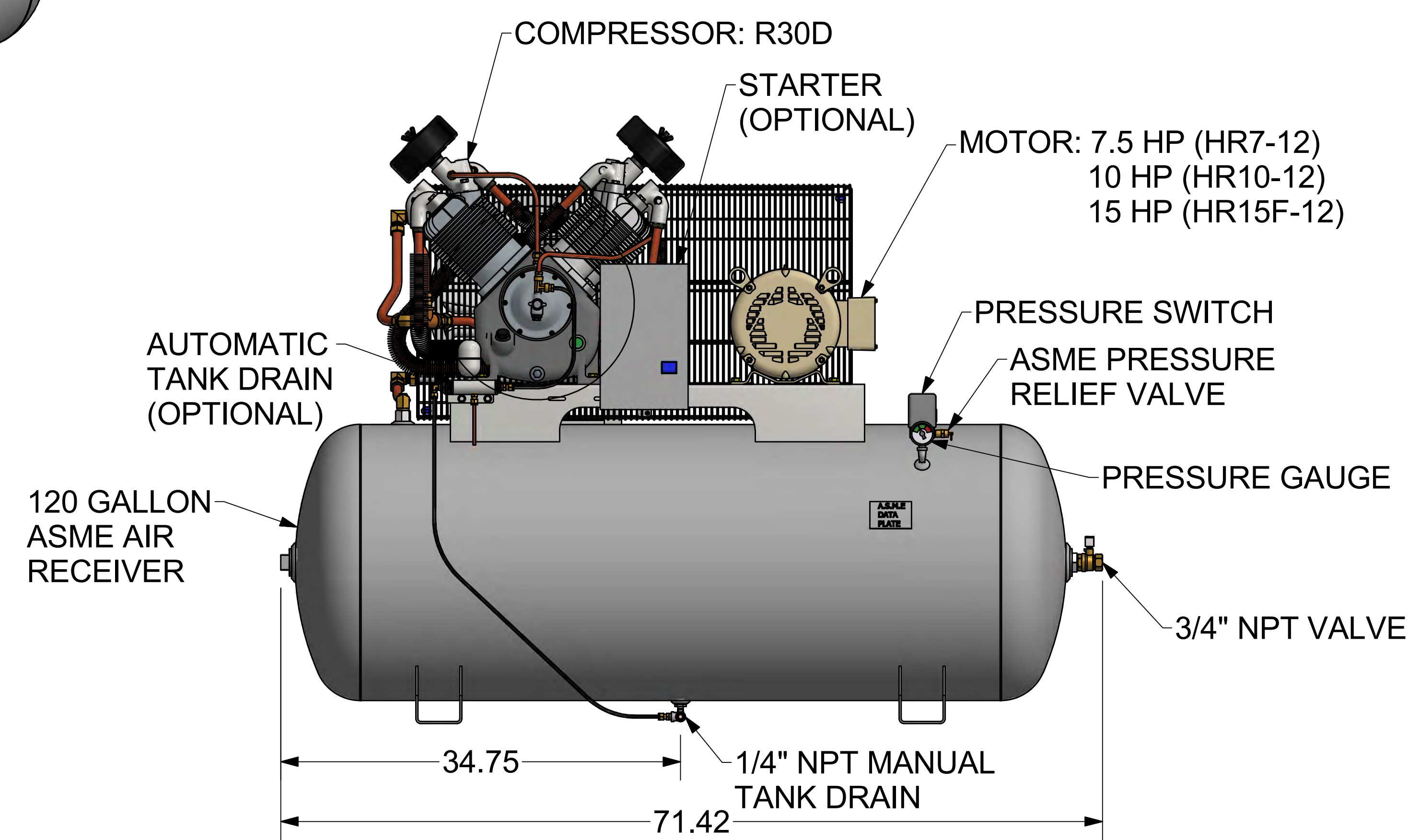
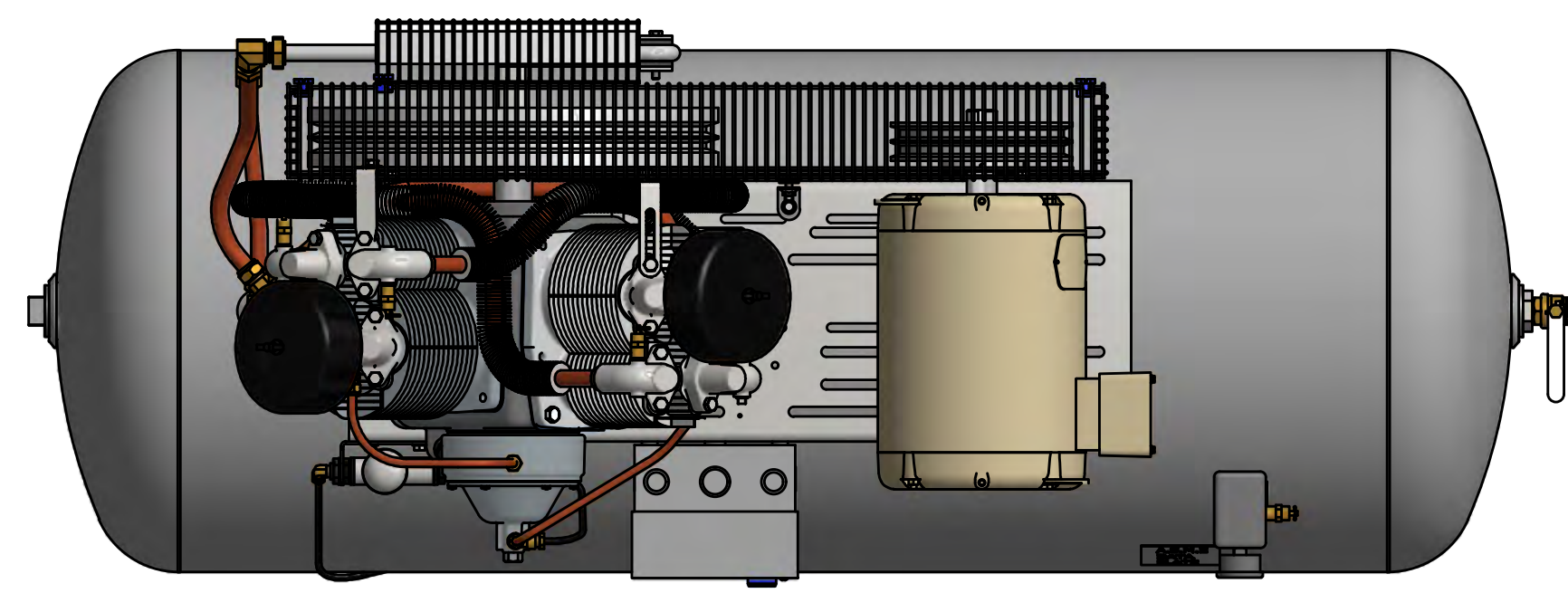
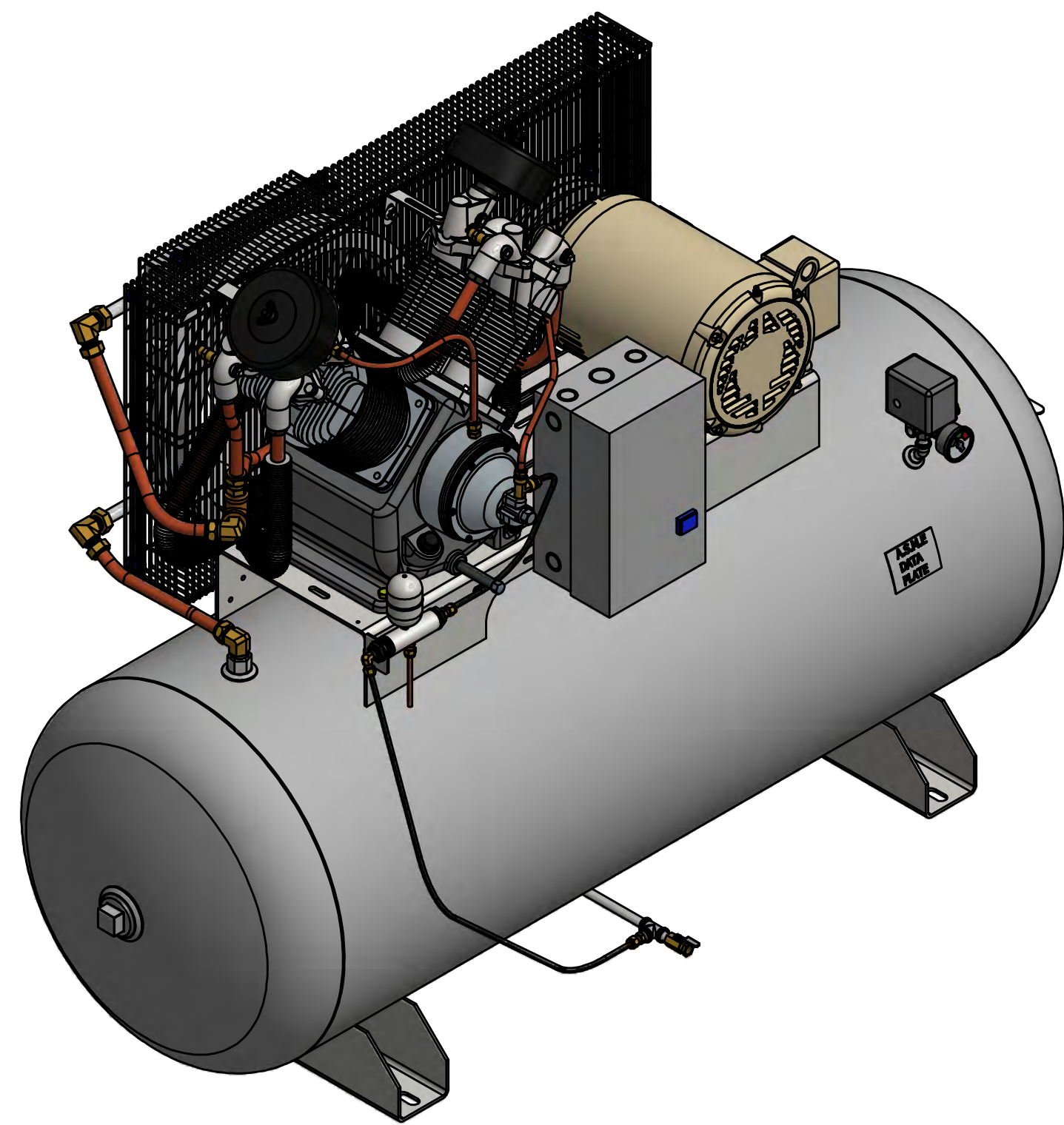

- NOTES:
- DO NOT SCALE DRAWING.
  - SPECIFICATIONS AND DIMENSIONS ARE SUBJECT TO CHANGE WITHOUT NOTICE OR OBLIGATION.
  - ALL DIMENSIONS ARE IN INCHES.
  - ADD 1.00" TO HEIGHT FOR VIBRATION ISOLATION OPTION.

FINISH OF CHAMFERS AND FILLETS TO CONFORM TO ROUGHEST ADJACENT AREA. SURFACE ROUGHNESS MAXIMUM PER ASME B46.1. FULL THREAD DEPTHS ARE MINIMUM.		CONFIDENTIAL - THE INFORMATION CONTAINED IN THIS DOCUMENT IS THE PROPERTY OF GARDNER DENVER, INC. IT IS NOT FOR PUBLIC DISCLOSURE. POSSESSION OF THE INFORMATION DOES NOT CONVEY ANY RIGHT TO LOAN, SELL OR DISCLOSE THE INFORMATION. UNAUTHORIZED REPRODUCTION OR USE OF THE INFORMATION IS PROHIBITED. THIS DOCUMENT IS TO BE RETURNED TO GARDNER DENVER, INC. UPON THE COMPLETION OF THE PURPOSE FOR WHICH IT IS LOANED OR UPON REQUEST.			
UNLESS OTHERWISE SPECIFIED DIMENSIONS ARE IN INCHES		DIMENSIONING AND TOLERANCING PER ASME Y14.5-2009 THREADS PER ASME B1.1 GAGING SYSTEM 21 U.O.S., ANSI B1.20.1 & B1.20.3			
TOL. ON DECIMALS: .X = ± .05 TOL. ON DECIMALS: .XX = ± .02 TOL. ON DECIMALS: .XXX = ± AS SPECIFIED TOL. ON ANGLES: ± 0°-30'		Gardner Denver		HEAT TREATMENT	
THIRD ANGLE PROJECTION		Gardner Denver Inc. Quincy, IL.		ENG. REF:	
DWN BY KWT 10/9/2013		TITLE OUTLINE-BARE UNIT		REV A	
CKD BY DA 10/9/2013		SCALE 1/7		SHEET 1 OF 1	